

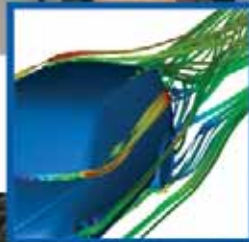

EnginSoft International Conference 2009

500 attendees from around the globe, from various industries, research and academic institutions came together to hear and discuss how CAE Computer Aided Engineering and Virtual Simulation Technologies can innovate and perfect today's product development

Designing low-emission cars with modeFRONTIER and Sculptor: external shape aerodynamic optimization



Solar Industry, numerical simulation and optimization

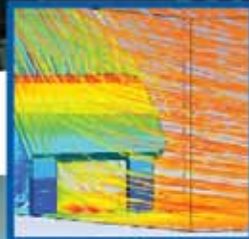

Multi-objective optimization of an aluminium automotive part using modeFRONTIER

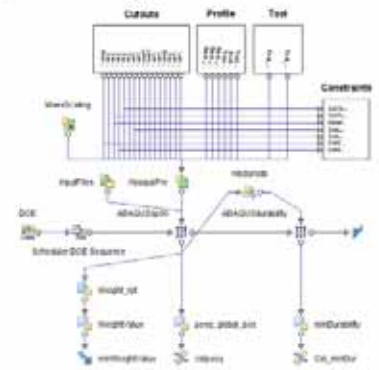

Optimization software drives Multi Body simulations in a Circuit Breaker design at ABB

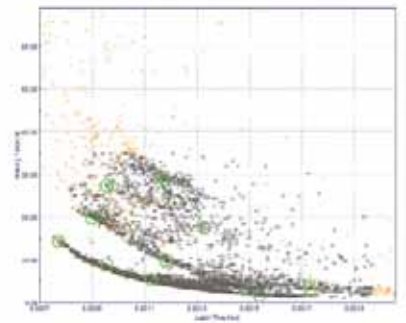

The optimal solution of a mixture problem with modeFRONTIER

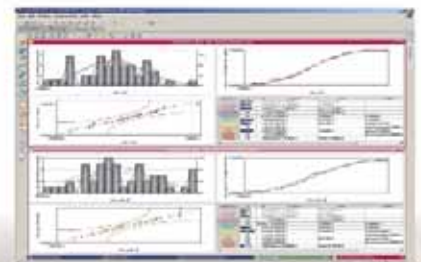

Multi-objective optimization of an aluminium automotive part using modeFRONTIER

In a high-cost country such as Norway it is very important that high volume products, for example automotive parts, are designed and produced in the most cost-efficient way. For aluminium components, the weight is of special interest due to the significant cost of the raw material. Lighter components are also rewarded by a higher price on the market and, in addition, help us to preserve our environment by lower fuel consumption.

Simulation of manufacturing processes still poses challenges and requires experience in order to get reliable results in an efficient way. A good example is forming with springback, especially if the component is formed in multiple operations. With the technology of today, is it possible to automate the search for the best design in this environment, something which would be highly desirable?

Despite many potential problems, a challenging project aiming at automatic search for the optimal design of an automotive wheel suspension component was started. In the project team, SINTEF Raufoss Manufacturing AS added expertise in manufacturing and materials technology, A-Dev brought expertise in nonlinear analysis and automation while EnginSoft Nordic AB focused on optimization methodology.

Motive

The project is part of the Norwegian research program AluPart which aims to "secure future production of aluminium-based automotive components within Norway" by "inventing, developing and industrializing new and radically improved manufacturing technology". The ability to steer

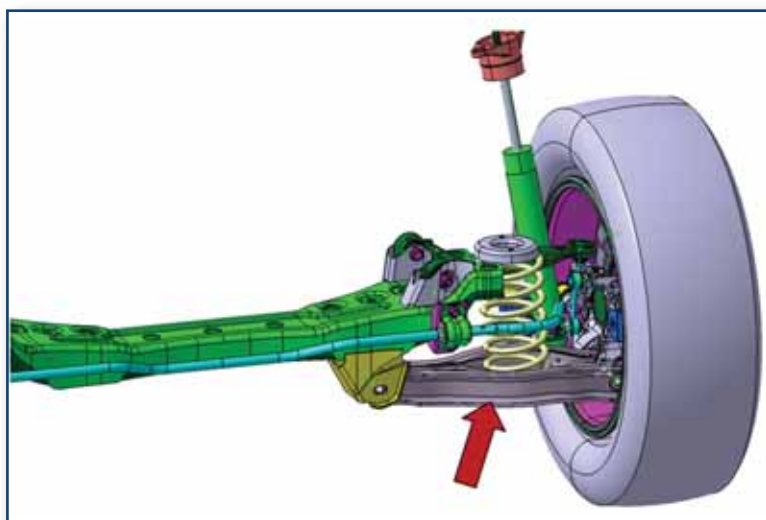

Figure 1. The goal of the project was to find the optimal design of the control arm through an automatic search. The control arm links the wheel to the body of the car.

automatic design processes towards the specified goals is recognized as a key technology which will be of great value to the industry, provided it works on real world problems, may be applied to virtually any engineering analysis and is easy to understand and use by the local engineer.

An automotive control arm, made from an extruded aluminium

profile, was chosen for the study, cf. figure 1. Simulation models and a baseline design were provided by Raufoss Technology AS who is a leading manufacturer of aluminium control arms. In 2006, their production exceeded 1.4 million complete control arms, delivered to companies like GM, Fiat, Hyundai and Kia. Some examples of their products may be seen in figure 2.

The challenge

The study aimed at finding, through automatic search methods, the best design with respect to cost, performance and manufacturability. The cost value focuses on material cost and takes recycling of cut material into account. The performance is measured by the durability of the component, i.e. the number of loading-unloading cycles it can withstand without fracturing. Also, the deformation of the material during the forming operations is not allowed to exceed a certain limit.

The component is made from an extruded aluminium profile which is cut and formed in multiple steps to its final shape, cf. figure 3. To capture the manufacturing process, a combination of explicit and implicit FE analyses was performed in ABAQUS. While forming used explicit integration, springback and the final fatigue evaluation used implicit integration.

In order to find the best design it was not sufficient just to optimize the shape of the extruded profile, but rather the whole manufacturing process must be optimized, including the shape of the aluminium profile as well as the shape of the cutting and forming tools.



Figure 2. Raufoss Technology AS is an innovative company that designs and produces automotive components in aluminium. The studied control arm is produced according to the patented ExtruForm® process.



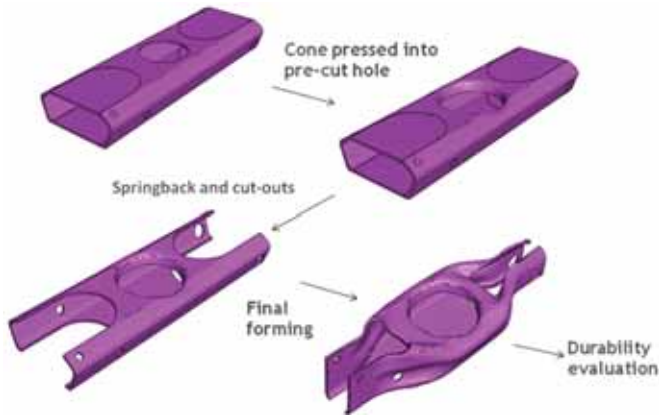

Figure 3. The control arm is formed and cut in multiple operations before the final durability evaluation.

Furthermore, the optimization was performed using "no prior knowledge", meaning that no engineering knowledge of good designs or the base-line design was included in the starting set of the optimization. On the contrary the specified ranges for the input parameters were chosen to be wide on purpose. The aim was to build a methodology independent of prior engineering insight of the problem. This approach, of course, puts the highest demands on the optimization algorithm. Thinking ahead, any prior good design that may be provided as a starting condition for the optimizer may dramatically reduce the number of required design iterations.

The solution

modeFRONTIER was used to link multiple cutting and forming FE simulations into an automatic process and guide it towards the specified objectives. The automated operation included the pre-processing with its geometry change and remeshing, and post-processing including a durability evaluation. Altogether 22 parameters controlled the

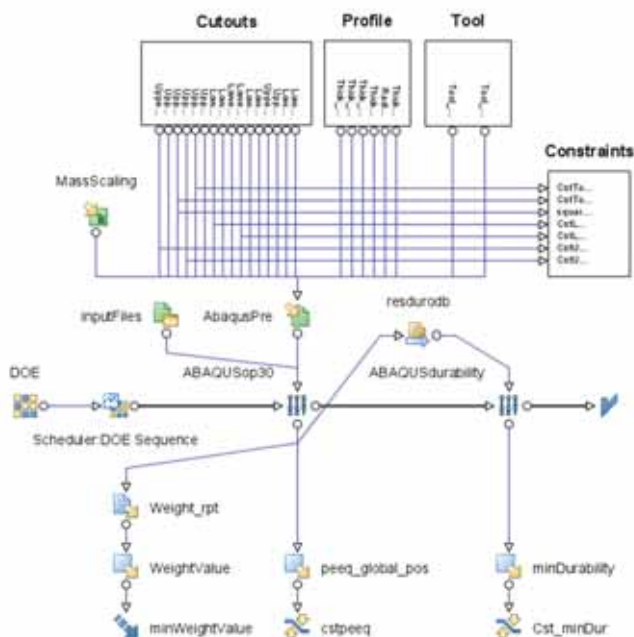

Figure 4. modeFRONTIER was used to automate multiple forming operations in ABAQUS and steer the search for the best design. The 22 input variables are shown at the top.

geometries of the extruded aluminium profile and the tools. The workflow in modeFRONTIER can be seen in figure 4. An automatic search for the best design requires numerous design evaluations and speeding up each evaluation is often very attractive. As such, modeFRONTIER promotes a trend opposite to the common search for ever more detailed and accurate simulation models. With regards to the automatic process, we only need an accuracy of the results which makes sure the optimizer is guided to the global optimum. Final tuning and validation may be done with high fidelity as part of a hybrid optimization strategy, while the search for the optimum makes use of a faster, approximate model. But what accuracy of the results is good enough for the global search? By sampling the design space and evaluating

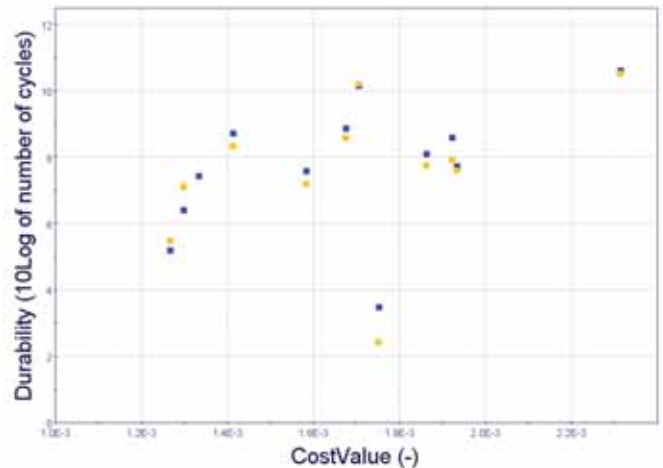

Figure 5. A set of designs are evaluated with two different mass scalings. For each design the cost value is constant and the two points should ideally overlap. The difference in results from the original and the 10 times faster model is small compared to the design space and the Pareto front.

models with different levels of accuracy, it is possible to arrive at an engineering answer. In the forming analysis a significant time saving could be achieved by an increased mass scaling. In figure 5, showing a comparison of calculated durability between two levels of mass scaling, it can be seen that the difference between the two levels are relatively small compared to the size of the results space and the size of the Pareto front, both regarded as relevant relative measures. As the validation has been done on the entire design space rather than a single design, it is likely that the conclusion is valid also for similar components. Being a side effect of this optimization project, the faster approximation may be trusted to help speed up manual design work as well.

Because of the mentioned findings, a multi-level hybrid optimization strategy was selected, including a multi-objective global search, a single-objective local refinement and a final verification. The first two optimization phases used simulation models with significant speed-up due to a higher mass scaling in the explicit forming steps. Following the first two optimization phases a verification phase was performed with the original mass scaling to ensure reliable and comparable results.



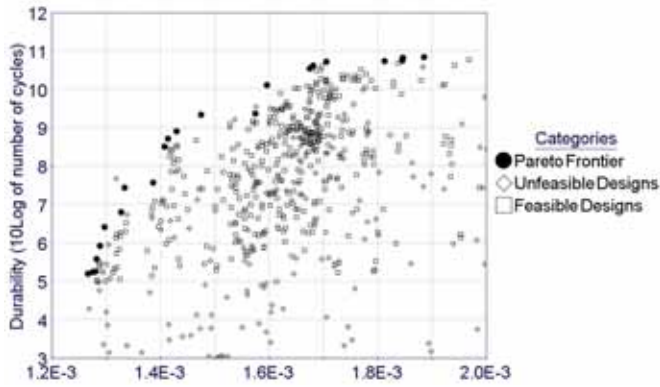

Figure 6. The Pareto front from the initial multi-objective search shows the trade-off between material cost and durability of the control arm.

In the initial study, a multi-objective optimization problem was defined to simultaneously minimize the material cost and maximize the durability while keeping the plastic strain below a specified limit during forming operations. This optimization mapped, in a pedagogical way, the trade-off between the cost and the durability, cf. figure 6.

Once the relationship between the cost and the durability was mapped in the multi-objective optimization, the problem was restated in single-objective form aiming to minimize the material cost while respecting the requirements for durability and maximum allowed plastic strain. In the final phase of the optimization, the designs

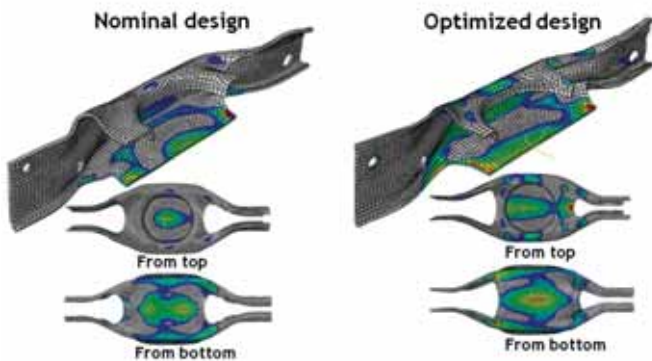

Figure 7. As expected, a larger volume of the material is stressed in the optimized design while the peak value has been decreased. The plot shows expected fatigue life, red being lowest and light grey highest.

from the previous optimization phases were verified with the reference mass scaling, and from this optimization/verification the final design, cf. figure 7, was found.

During the optimization process many designs failed to complete all analysis operations, and thus to deliver a result. A sampling with 650 designs over the full parameter range was performed to investigate this issue. The result, shown in figure 8, reveals that less than 10 percent of the designs managed to succeed. The majority of the designs failed due to geometry build failures, elements exceeding the distortion limits and non-convergence in springback calculations. While a geometry build error may be detected

and recovered from in the order of seconds, errors like non-convergence in the final springback analysis may degrade the performance of the search significantly. Due to the low success rate this optimization task was a real challenge for the search algorithm. Nevertheless, modeFRONTIER was able to run continuously for hundreds of hours on a heavily loaded PC in a persistent search for the best designs.

Results

An automatic process for the forming and cutting operations was created and a hybrid optimization methodology was tested and verified. Besides the best design, several soft values came out of the project such as systematic identification and ranking of simulation error sources.

The optimized design reduced the material cost by 25 percent while fulfilling the constraint on the maximum allowed plastic strain during the forming operations. At the same time, the durability increased from 13 000 to 1 700 000 load cycles.

Conclusions

In the context of product development, the applied multi-level hybrid optimization strategy was well justified and is recommended for future work.

The automatic optimization process managed to:

- find the best design despite many analysis crashes.
- find the best design using a “no prior knowledge”-approach.
- reduce the material cost with 25 percent with increased durability and fulfilled manufacturing constraints.

Some work still remains in order to have a process ready to use in the everyday design work by the manufacturing companies, but the results are promising and modeFRONTIER has proved to be a robust and powerful tool for automating the forming analyses and finding the best design.

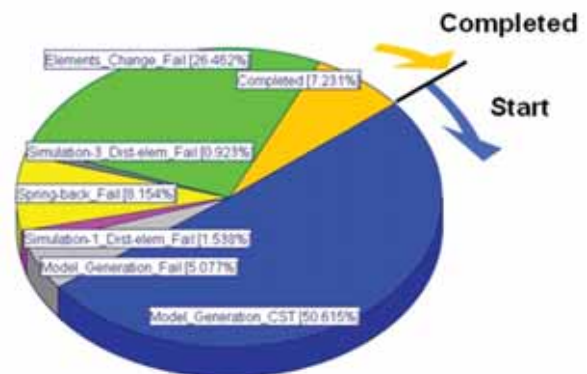

Figure 8. A sampling of 650 designs over the full input parameter space revealed the different simulation error sources. Less than 10 percent of the designs completed successfully.

Tomas Andersson, A-Dev
 Håkan Strandberg, EnginSoft Nordic AB
 Steinar Sørbø, SINTEF Raufoss Manufacturing AS

